

Design of a computerized, temperature-controlled, recirculating aquaria system

Ann M. Widmer^{*}, Corissa J. Carveth, John W. Keffler, Scott A. Bonar

*Arizona Cooperative Fish and Wildlife Research Unit, U.S. Geological Survey,
University of Arizona, 104 Biosciences East, Tucson, AZ 85719, United States*

Received 13 November 2005; accepted 15 November 2005

Abstract

We built a recirculating aquaria system with computerized temperature control to maintain static temperatures, increase temperatures 1 °C/day, and maintain diel temperature fluctuations up to 10 °C. A LabVIEW program compared the temperature recorded by thermocouples in fish tanks to a desired set temperature and then calculated the amount of hot or cold water to add to tanks to reach or maintain the desired temperature. Intellifaucet[®] three-way mixing valves controlled temperature of the input water and ensured that all fish tanks had the same turnover rate. The system was analyzed over a period of 50 days and was fully functional for 96% of that time. Six different temperature treatments were run simultaneously in 18, 72 L fish tanks and temperatures stayed within 0.5 °C of set temperature. We used the system to determine the upper temperature tolerance of fishes, but it could be used in aquaculture, ecological studies, or other aquatic work where temperature control is required.

© 2005 Elsevier B.V. All rights reserved.

Keywords: Temperature control; Recirculating; Mixing valves; Fluctuations; Temperature tolerance

1. Introduction

Temperature affects almost all biochemical, physiological, and life history activities of fishes (Beitinger et al., 2000). Consequently, water temperature is a vital aspect of fish habitat. Stream temperatures have been altered by water released from reservoirs, water diversions, channel alterations, loss of riparian vegetation, and other land use practices in the last century (Poole and Berman, 2001). High water temperatures cause stress in fish and create conditions that favor disease outbreaks, as seen in the large fish kill in the Klamath River, CA, in 2002 (California Department of Fish and Game, 2003). Changes in water temperature also can render streams uninhabitable to some native

fishes. Elevated stream temperatures may have contributed to the sharp decline in native fish populations of the southwestern United States, many of which have been listed as threatened or endangered under the U.S. Endangered Species Act (Minckley and Douglas, 1991). Studies are needed to define the habitat requirements of fish so effective conservation measures can be implemented. Thermal tolerance studies define a significant aspect of these habitat requirements.

Traditional laboratory studies of thermal tolerance either slowly heat water from an acclimation temperature or suddenly expose fish to a fixed water temperature above or below a predetermined acclimation temperature (Fry, 1967). Neither method adequately approximates natural stream conditions. Natural stream temperatures fluctuate on a diel cycle (Sinokrot and Stefan, 1993), and the amplitude of fluctuations may increase with diminishing stream flows (Poole and Berman, 2001). Realistic diel temperature fluctuations

^{*} Corresponding author. Tel.: +1 303 722 7626.

E-mail address: widmer@gmail.com (A.M. Widmer).

need to be reproduced in the laboratory in order to obtain temperature tolerance results that are relevant to management of wild fishes. This paper describes the aquaria system built to conduct thermal tolerance studies with fluctuating temperatures found in Widmer (2004) and Carveth (2004).

To test the upper thermal tolerance of native desert fishes, we built a system with 18 fish tanks that could simultaneously maintain six different water temperature fluctuations up to 10 °C in amplitude. The system may have been capable of larger fluctuations, but 10 °C was the largest fluctuation tested. Similar systems using flow-through water supplied by natural springs have been constructed for thermal tolerance studies of some salmonids (Selong et al., 2001; Johnstone and Rahel, 2003). Because comparable water resources were not available in southern Arizona, we used a recirculating water system. Water from all tanks had to be mixed before being recirculated and all tanks had to turn over at the same rate to maintain similar water quality among all fish tanks. Furthermore, water temperatures in fish tanks had to remain within 0.5 °C of the desired temperature.

Six fluctuating temperature treatments were run simultaneously, each having a different temperature range. In addition to maintaining temperature fluctuations, the system had to be capable of maintaining static temperatures and increasing water temperatures at a set rate. A personal computer (PC) recorded water temperatures and directed computerized mixing valves to maintain set temperatures in fish tanks by adding hot or cold water.

Although our temperature-control system was used for thermal tolerance studies, it could have many other applications. The system could simulate seasonal changes in water temperature, which may help stimulate fish to spawn in hatcheries or aquaculture facilities. If the system were built on a larger scale, tests could be conducted to determine the optimal temperature or temperature fluctuation for growth of commercial fishes in captivity. This system also could be used to evaluate fish feeding efficiencies or to develop bioenergetics models under controlled thermal regimes. Elements of this system may be helpful in any application requiring controlled temperature changes, including systems with a flow-through water supply.

2. Materials

2.1. Fish tanks and plumbing

Fish were held in 18 aluminum trough-type fish tanks (122 cm × 36 cm × 25 cm tall). Each tank had a

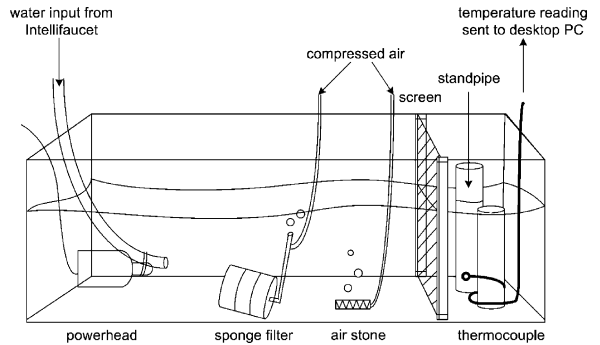

Fig. 1. Arrangement of objects in the fish tanks.

perforated stainless steel screen 15 cm from the foot of the tank to separate the fish holding area from drain standpipes. Standpipes were made of PVC. Water depth was 17 cm during experiments, so each fish tank contained 72 L of water. Tanks were insulated on the sides and bottom with 5 cm thick rigid polystyrene foam-board and covered with a 2.5 cm thick foam-board lid, which contained a small screened window to allow light penetration. A powerhead (Rio 1100) at the head of each fish tank mixed the water and provided stream-like water current (Fig. 1). Each tank had a sponge filter to denitrify water and provide fish with refuge from current. Air stones supplemented oxygen in the tanks.

Hot water was plumbed with schedule 80 CPVC and all other plumbing was done with schedule 40 PVC. No copper or brass was used in the water plumbing because they are toxic to many fish species (Piper et al., 1982). Water going to the fish tanks was plumbed 1 m above the tanks and water leaving the tanks was plumbed 0.75 m below to increase space efficiency and utilize gravity water flow. A float valve wired to a pump regulated water levels in the biofilter tank, and large plastic float valves ensured that recirculated water filled both the hot and cold 1170 L circular fiberglass starting tanks (Fig. 2). Compressed air was plumbed into a 5 cm PVC pipe that ran above the tanks. This pipe was tapped with small plastic spigot valves and flexible vinyl aquarium air hose to supply air to sponge filters and air stones in fish tanks.

2.2. Water filtration

Water from all fish tanks drained into an 1800 L biofilter tank, where it ran through a series of four polyester filter pads (122 cm × 61 cm × 3 cm thick) cultured with nitrifying bacteria. After leaving the biofilter tank, water was run through two canister filters (15.2 m² surface area, 20 μm, Aquatic Ecosystems

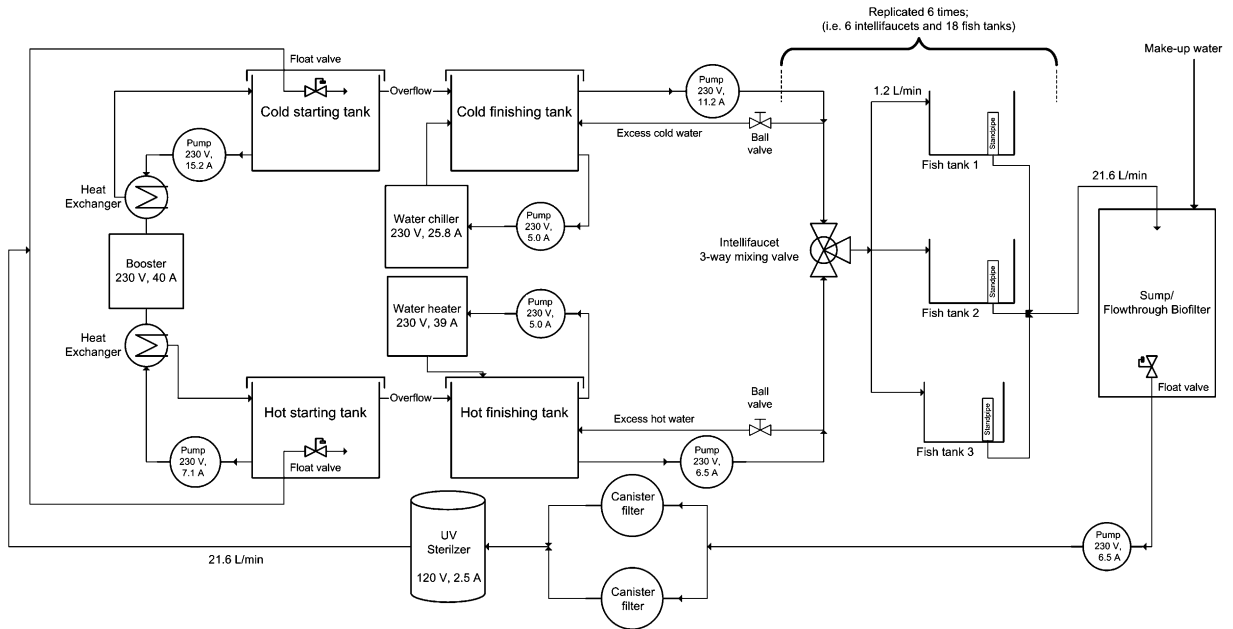

Fig. 2. Diagram of recirculating aquaria system (not to scale).

CCF50R) and a UV sterilizer (Emperor Aquatics Model # COM6390-UL, 120 V, 2.5 A) before refilling the two starting tanks.

Most feces and uneaten food in fish tanks was trapped behind the perforated screen at the foot of the tank and siphoned out daily. Other waste accumulated in the biofilter and canister filters. Pads in the biofilter tank had to be removed periodically and sprayed with water to remove large particles. Canister filters also needed to be cleaned periodically. The two canister filters were plumbed in parallel, so water could be run through one while the other was removed for cleaning. Nitrates and nitrites levels, estimated using test kits, were always below detectable levels during our experiments.

2.3. Heating and cooling

Water returning from temperature treatments mixed in the biofilter tank and had to be heated or cooled before being returned to fish tanks. Although it would have been more energy efficient to build two separate recirculating systems, one for high temperature treatments and one for lower temperature treatments, mixing water from all treatments was the best way to maintain comparable water quality among fish tanks.

After filtration, water ran into the hot and cold starting tanks. The temperature of ambient water at the well-head ranged from 23 to 29 °C. However, because the system was recirculating, the temperature of the water entering the starting tanks varied over time from

about 25 to 33 °C as a result of changes in test temperatures. Both starting tanks were plumbed into a temperature booster that simultaneously heated water in the hot starting tank to 35 °C and chilled water in the cold starting tank to 20 °C (5 tonnes compressor, 230 V, 40 A, University of Arizona, patent pending). Water from the starting tanks overflowed into hot and cold 1170 L circular fiberglass finishing tanks. Water in the cold finishing tank was further cooled by a water chiller to 10 °C or lower (Aquanetics model AFC-11, 230 V, 25.8 A). The water chiller was located outside the building so that hot air blown off would not raise the ambient temperature in the building. Water in the hot finishing tank was brought up to 45 °C by a water heater (Aquanetics model TH9000, 230 V, 39 A).

Water was pumped from the hot and cold finishing tanks to six Intellifaucets[®] (Hass Manufacturing Company, model K250SS), computerized three-way mixing valves primarily used for photograph developing. The Intellifaucets[®] were plumbed in parallel and were constantly supplied with an excess amount of hot and cold water from the finishing tanks. Excess water returned to the finishing tanks. Each Intellifaucet[®] mixed water for one temperature treatment and supplied water to three fish tanks. Flow from Intellifaucets[®] could be programmed as a percentage of the available flow. The available flow of the system was estimated by using a measured container and a stopwatch and then adjusted appropriately. One third of the tank volume was replaced every 20 min with water from the

Intellifaucets[®], so the water in the tanks turned over once per hour at a mean rate of 1.2 L/min. Water moved through the whole recirculating system at a rate of 21.6 L/min. In case of power failure, all valves and pumps in this system would shut down. Therefore, water that was too hot or too cold would not be delivered to the tanks, and temperature shock to fish would be prevented.

2.4. Computerized temperature control

The Intellifaucets[®] controlled water temperature in fish tanks and were remotely controlled through a National Instruments PCI 6704 16-bit static analog output board installed in a desktop PC (Fig. 3). Water temperature in fish tanks was measured with Omega T-type thermocouples and a National Instruments SCB-68 shielded connector block. The SCB-68 was connected to a National Instruments PCI 6023e data acquisition board installed in the desktop PC. Each thermocouple channel was set to single end reference mode, and the thermocouples were calibrated against a mercury thermometer calibrated in increments of 0.1 °C. The thermocouple exhibited an offset from the calibration temperature, which we corrected in the software by a simple linear correction factor. The accuracy of thermocouples was determined to be ± 0.5 °C from calibration tests. The size of the SCB-68 shielded connector block limited us to 14 thermocouples for the

18 fish tanks. Of the three fish tanks supplied by one Intellifaucet[®], at least two tanks had thermocouples placed in them. Although temperatures were recorded from all thermocouples every 5 min, each Intellifaucet[®] was controlled by the feedback of only one thermocouple. Thermocouples were fastened to stand-pipes located on the opposite end of each fish tank from the water inlet hose. The thermocouple location helped to ensure that water mixed throughout the tank before temperature was measured.

Water temperatures in fish tanks were controlled by programs written in LabVIEW (version 6.1, National Instruments) installed on the desktop PC. Programs compared the measured tank temperature to a desired set temperature and then calculated the desired input water temperature. This input water temperature was then sent to the Intellifaucets[®], which mixed hot and cold water to the input temperature and added a set volume of water to fish tanks. The calculation of the input water temperature was derived from a simple energy balance approach shown in Eq. (1), where T_{line} is the temperature of water to be added, T_f the set temperature, T_i the initial measured temperature, and x the amount of water to be added to a tank. It was assumed that there was no heat loss from fish tanks and that the specific heat of water was constant over our range of temperatures. For our tests, 30% (or $x = 0.3$) of the tank volume was added every 20 min. Adding water at intervals allowed us to maintain set temperatures without exceeding our supply of hot and cold water:

$$T_{\text{line}} = \frac{T_f - T_i(1 - x)}{x} \quad (1)$$

3. Methods

We evaluated the system while it was running three different temperature programs for a total of 50 days of operation. During these temperature programs, we were conducting experiments designed to test the upper temperature tolerance of loach minnow (*Tiaroga cobitis*) and spikedace (*Meda fulgida*) held at light densities.

In the first program, all 18 fish tanks were maintained at a constant 25 °C for 14 days. In the second program, temperatures in six tanks were increased step-wise by 1 °C/day from 30 to 35 °C through two Intellifaucets[®] with the temperature increase occurring at 00:00 h each day. In the third program, each Intellifaucet[®] was programmed to run a different diel temperature fluctuation for 30 days: 28–32, 26–32, 22–32, 30–34,

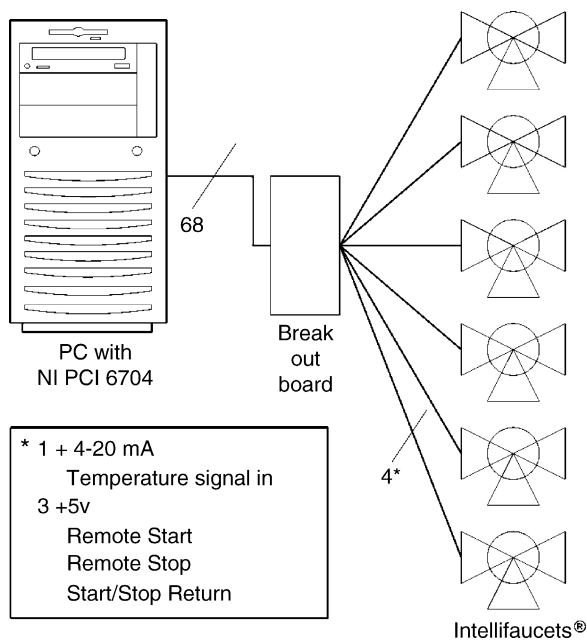

Fig. 3. Diagram of wiring to Intellifaucets[®].

28–34, and 24–34 °C. Fluctuations were sinusoidal over a 24 h period, with the highest temperature reached at 15:00 h and the lowest temperature at 03:00 h.

Thermocouple readings were recorded by LabVIEW in a text file. In order to monitor changes in water temperature and identify problems, we imported this file into Microsoft Excel and graphed the data daily. Water temperatures were taken manually twice daily with digital thermometers to validate thermocouple records. Digital thermometers were calibrated against the same mercury thermometer as the thermocouples.

Thermocouples were subject to electrical noise and occasionally recorded outlying temperature readings that we assumed were false (e.g., $-84,708$ °C). Before analyzing temperature readings, we deleted isolated measurements that were more than 5 °C different from the measure immediately preceding and following it. Outlying temperature measurements that were recorded more than once in succession were assumed valid and were included in the analysis. Data from periods when the system was not working properly were analyzed separately and the reasons for failure documented. After Program 1 was completed, the SCB-68 shielded connector block was covered with fiberglass insulation to minimize the influence of ambient temperature swings, and the linear correction factor for thermocouples was refined. Also, the temperature booster was not used while running Program 2 as it required maintenance.

We used two-tailed Student's *t*-tests to compare thermocouple readings to programmed temperatures and temperatures recorded manually. Thermocouple readings also were compared among the six different Intellifaucets[®] and among the fish tanks supplied by the same Intellifaucet[®] for each of the three temperature programs. Data were analyzed in JMP Version 4.0.4, 1989–2001.

4. Results

4.1. Program 1: all 18 fish tanks programmed to maintain constant 25 °C for 14 days

Eighteen out of 10,010 thermocouple readings were deleted prior to analysis. The system was functional 100% of the time. The mean thermocouple measurement for all fish tanks and for all dates grouped together was 25.2 °C (S.D. = 0.35, $N = 9992$). The difference of 0.2 °C between the mean thermocouple measurement and the programmed 25 °C is smaller than our detection level of 0.5 °C. Mean daily temperatures recorded by the thermocouples ranged from 25.1 to 25.3 °C over the 14-day period. Mean differences in thermocouple readings among tanks on the same Intellifaucet[®]

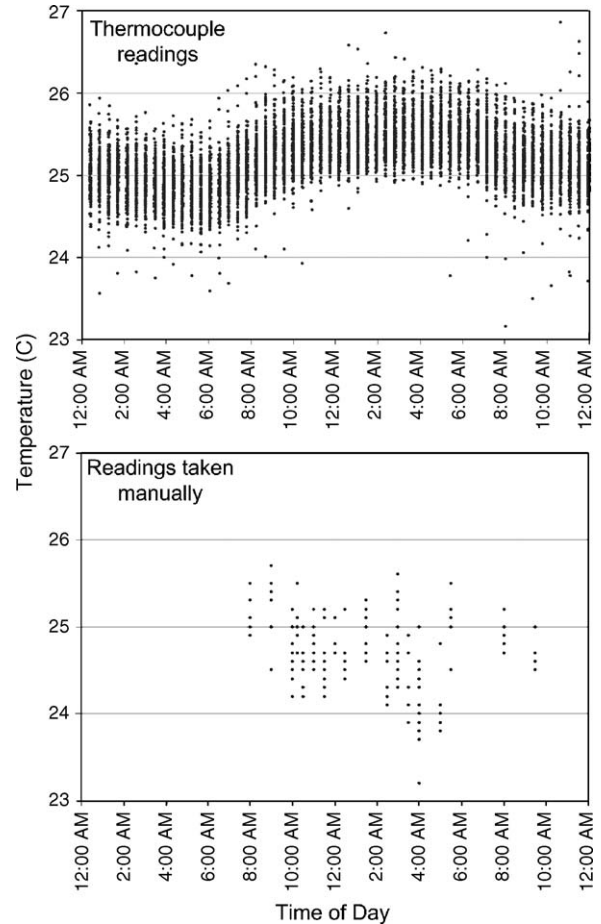

Fig. 4. Temperature changes over 24 h during 14 days of Program 1: constant 25 °C.

ranged from 0.0 to 0.1 °C, except for one Intellifaucet[®] where the mean difference between tanks was 0.7 °C. Mean thermocouple readings for the 14-day period grouped by Intellifaucet[®] ranged from 25.0 to 25.3 °C.

Thermocouple readings fluctuated over a 24 h period (Fig. 4), ranging from a mean of 24.8 °C (S.D. = 0.27, $N = 364$) at 16:45–17:15 h to a mean of 25.4 °C (S.D. = 0.29, $N = 306$) at 14:45–15:15 h. The same pattern is not apparent in readings taken manually, although no readings were taken manually between 21:30 and 08:00 h. Mean daily temperature recorded by thermocouple was 0.4 °C higher (95% CI 0.2–0.6) than those recorded manually (paired *t*-test, $t_{13} = 4.49$, $P < 0.001$).

4.2. Program 2: stepwise increase 1 °C/day from 30 to 35 °C in 6 fish tanks

Seven out of 2175 thermocouple readings were deleted prior to analysis. The system was functional

100% of the time. After the new linear correction factor was applied to thermocouple readings and the SCB-68 connector block was insulated from the ambient temperature, thermocouple readings were only 0.1 °C higher (95% CI 0.0–0.3) than readings taken manually, and the difference was not significant (paired t -test, $t_{22} = 2.00$, $P = 0.06$). The mean difference in tank temperatures averaged for each Intellifaucet[®] was 0.2 °C (S.D. = 0.47, $N = 542$). Only two Intellifaucets[®] were used in Program 2, and the mean difference in temperature among fish tanks was 0.08 (S.D. = 0.16, $N = 542$) on the first Intellifaucet[®], and 0.08 (S.D. = 0.70, $N = 542$) on the second. After the set temperature increased 1 °C at 12:00 a.m., fish tank temperatures increased and became stable within 30 min to 1 h.

The mean tank temperature was consistently lower than the set temperature, and the difference grew as the set temperature was increased (Fig. 5). The difference between actual and set temperatures became greater than 0.5 °C when the set temperature reached 35 °C.

4.3. Program 3: six different diel temperature fluctuations for 30 days

We deleted 42 out of 83,110 thermocouple readings prior to analysis. The system was run for 792 h and was functional 93% of that time. Data from the functional time and the non-functional time were analyzed separately.

Of the non-functional time, 43% occurred due to an error in Microsoft Excel that prevented LabVIEW from running in the background and went unnoticed for 24 h.

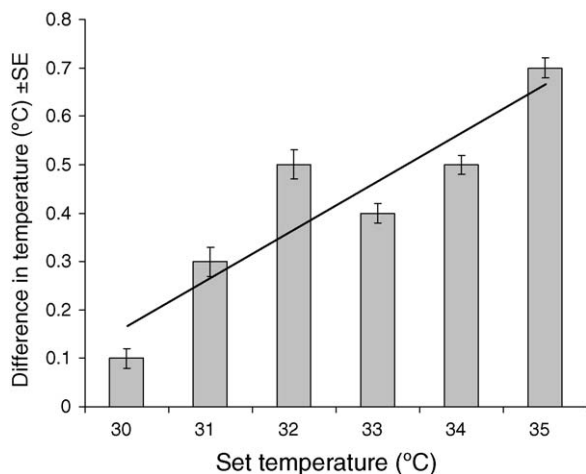

Fig. 5. Difference between fish tank temperature and set temperature as a function of the set temperature during Program 2: step increase 1 °C/day.

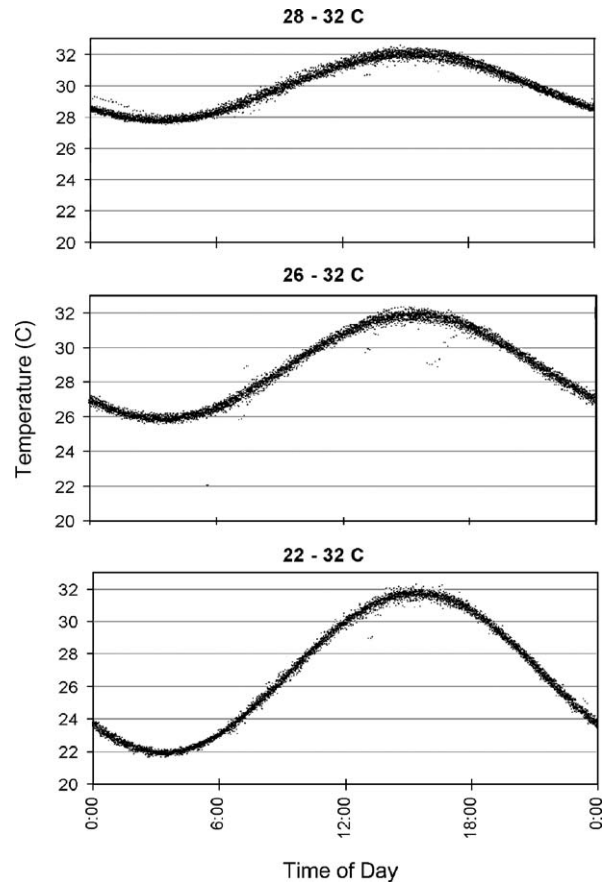

Fig. 6. Fish tank temperature grouped by time of day for treatments with 32 °C peak temperature during Program 3: 30 days of diel temperature fluctuations.

The water level in the hot finishing tank got too low one afternoon and prevented fish tanks from reaching their peak temperatures, accounting for 22% of the non-functional time. The remaining 35% non-functional time was caused when Intellifaucets[®] stopped communicating with the desktop PC after brief power outages. The connection with the computer was re-established by unplugging Intellifaucets[®] for a couple of seconds. Even when the system was not functioning properly, temperatures remained well within the range of the programmed temperature fluctuations.

When the system was functioning properly, all six diel temperature fluctuations remained within 0.5 °C of the set temperature throughout the day (Figs. 6 and 7). Small clusters of outlying thermocouple readings occurred when the thermocouple came in contact with the metal wall of a fish tank. The standard deviation around the set temperature was greater for the peak temperature than for the low temperature within a fluctuation cycle when grouped by Intellifaucet[®]

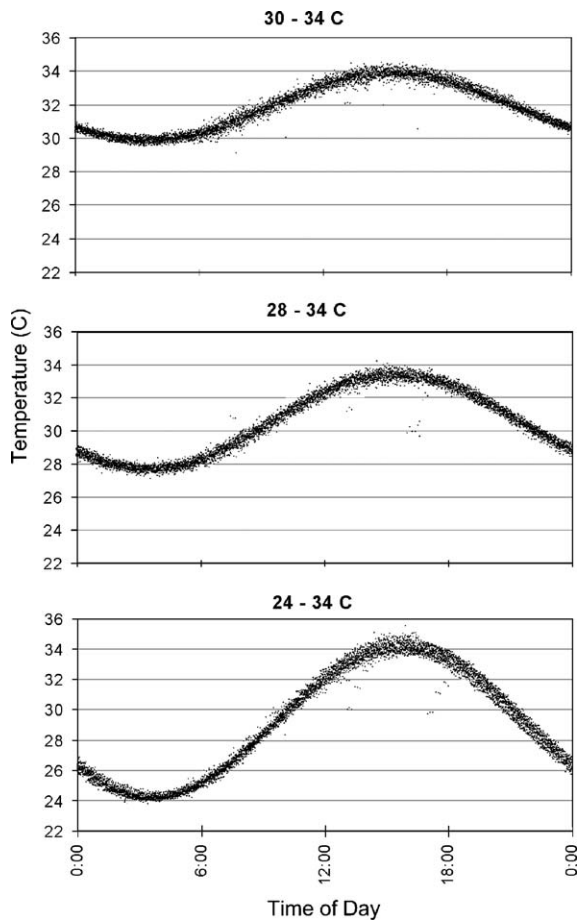

Fig. 7. Fish tank temperature grouped by time of day for treatments with 34 °C peak temperature during Program 3: 30 days of diel temperature fluctuations.

(Table 1). The greatest standard deviation in temperatures occurred in the 24–34 °C treatment, which was controlled by the same Intellifaucet[®] that had the largest temperature difference among fish tanks in Program 1.

Table 1

Low temperature at 03:00 h and peak temperature at 15:00 h for six diel temperature fluctuations in Program 3 while system was fully functional

Programmed temperature fluctuation (°C)	Mean at 03:00 h (S.D.)	Mean at 15:00 h (S.D.)
28–32	27.7 (0.13)	31.8 (0.26)
26–32	25.9 (0.18)	31.8 (0.25)
22–32	21.9 (0.12)	31.6 (0.23)
30–34	29.9 (0.19)	33.8 (0.30)
28–34	27.8 (0.18)	33.6 (0.29)
24–34	24.1 (0.27)	33.8 (0.61)

5. Discussion

After some of the initial faults were worked out of the system, it satisfied all of our test requirements: six different treatments ran simultaneously, temperatures stayed within 0.5 °C of set temperature, all fish tanks had the same water turnover rate, and the system used recirculated water that mixed during each cycle. The one exception was in Program 2 when tank temperatures were 0.7 °C below the set temperature of 35 °C. Although the system was functioning properly, the temperature booster was not run during Program 2 and the hot water supply appears to have been inadequate to maintain this high temperature.

Although significant differences existed between tanks on the same Intellifaucet[®], these differences were less than 0.2 °C in all but one case. Because the accuracy of our thermocouple measurements is ± 0.5 °C, we conclude that tank temperatures were nearly the same. Differences less than 0.5 °C are unlikely to produce significantly different physiological responses. The rate of flow directed to the three fish tanks from the one problem Intellifaucet[®] was slightly unequal, creating differences in temperatures among tanks. The rate of flow to tanks must be equalized. The higher standard deviation in peak water temperatures in all Intellifaucets[®] during Program 3 suggests that we had neared the limits of our hot water supply.

The non-functional time during Program 3 could have been greatly reduced by running only one computer program at a time and installing an alarm system. If LabVIEW was the only computer program running, negative interactions between computer programs could be avoided and error messages would be more prominent. Graphing thermocouple data daily in Microsoft Excel was vital to identifying problems in the system, but the application should have been closed before leaving the laboratory. The desktop PC had a back-up power source, but no alarm system. An alarm that notified us when a power outage or equipment failure occurred (Plaia, 1987; Lee, 2000) could have prevented the 24-h lapse in system operation. After power outage, it was important to check all Intellifaucets[®] to ensure connection to the PC was re-established.

Maintaining sufficient water levels in the finishing tanks was challenging. Water was lost due to evaporation and small leaks. In addition, we siphoned water out of the system every day when cleaning fish tanks. We manually changed roughly 5% of the water of the system each day for our experiments. However, an automated system to add water through float valves in the finishing tanks would have been more convenient.

During Program 1, thermocouple readings were influenced by changes in ambient air temperature. Because our air conditioning system could not maintain a constant ambient air temperature during the summer in Arizona, we had to thermally insulate the connector block. Thermocouple readings were not significantly different from temperature readings by a mercury thermometer once the correct linear correction factor had been applied to the LabVIEW program and the connector block was insulated. However, outlying thermocouple readings still were frequent. The precision of temperature measurements would be improved by using a National Instruments SCXI chassis rather than the PCI 6023e data acquisition board. Noise also occurred when the tip of a thermocouple touched the aluminum wall of a fish tank. This could have been prevented by more closely checking thermocouple position, or fastening thermocouples so they could not touch other objects.

The Intellifaucets[®] were very reliable for water temperature control in a laboratory setting, except immediately after a power outage. Fish tank temperatures usually remained within 0.5 °C of the set temperature, but the system could be further improved if thermocouples were placed in every fish tank and Intellifaucets[®] were controlled by the mean thermocouple readings for like tanks.

The equipment used in the rest of the recirculating system functioned well, except for the aluminum fish tanks. Corrosion was noted in these fish tanks, and we are currently coating them with plastic to avoid corrosion in the future. Some metals and plastics are toxic to fishes. We avoided use of copper or brass in any of our plumbing, and strived to use titanium or stainless steel whenever possible to lessen toxicity problems. We saw no indications of fish toxicity in our system during our experiments. Fish were housed in the system for months and we noticed no problems in either mortality or growth of our control fishes. The aluminum, which is relatively non-toxic to fish and acts as a sacrificial anode for the stainless steel, may have prevented ions from the more toxic stainless steel from releasing into the system and protected the more delicate stainless steel equipment (Huguenin and Colt, 1989). We will conduct tests with the new coated system before conducting future fish experiments to ensure the stainless steel does not corrode.

Water quality remained good at the low density of fish we tested (10–13 fish >40 mm total length in each tank), but additional filtration measures may need to be taken at higher fish densities. An additional heater and chiller on the starting tanks also could be used instead of a temperature booster.

In general we found this system highly successful for conducting research on the effects of temperature on small fishes. Modifications as discussed above would increase its efficiency. In its current design, this unit would be best suited for aquacultural research applications and less suited for aquacultural production. It could be used to estimate water temperatures at which growth and survival of the species of interest is optimized, and what holding densities are most appropriate at specific temperatures. It could also be used to fluctuate temperatures to encourage spawning of broodstock.

Data from our temperature tolerance experiments conducted in this system will be valuable to the conservation and management of native fish species in the Southwest. Computerized temperature control made long-term exposures to realistic temperature fluctuations possible. However, many other research, aquaculture, and hatchery projects would benefit from computerized temperature control and automated record-keeping. Elements of this system would function well in either flow-through or recirculating water systems to maintain narrow thermal conditions over time.

Acknowledgments

Funding and support for this study were provided by the U.S. Bureau of Land Management, Arizona Game and Fish Department, the University of Arizona, and T&E, Inc. We would like to thank James Ebeling, Freshwater Institute, Arlington, VA, for suggesting we use Intellifaucets[®] for water temperature control. Bill Matter and three anonymous reviewers provided helpful advice and commented on drafts of this paper. Kevin Fitzsimmons, Gary Dickenson, Bill Laughlin, Galen Bennett, Russell Tobiasson, Ian Pepper, and the rest of the staff at the Environmental Research Lab provided valuable advice on recirculating systems and aided in construction. Thanks also to Henry Perkins, Mechanical Engineering at the University of Arizona, for his comments on the design of the temperature booster and to Mike Munger, Facilities Maintenance at the University of Arizona, who built the unit. Al Zale, Tom McMahan, and Rick Barrows shared the design of their laboratory in Bozeman, MT, which helped greatly in the construction of our laboratory.

References

- Beitinger, T.L., Bennett, W.A., McCauley, R.W., 2000. Temperature tolerances of North American freshwater fishes exposed to dynamic changes in temperature. *Environ. Biol. Fish.* 58, 237–275.

- California Department of Fish and Game, 2003. September 2002 Klamath River fish kill: preliminary analysis of contributing factors. Available from <http://www.pcffa.org/KlamFishKillFactorsDFGReport.pdf> (October 13, 2004).
- Carveth, C.J., 2004. Upper lethal tolerance of spikedeace, *Meda fulgida*, exposed to chronic, static and fluctuating temperature treatments. MS thesis. University of Arizona, Tucson.
- Fry, F.E.J., 1967. Responses of vertebrate poikilotherms to temperature. In: Rose, A.H. (Ed.), Thermobiology. Academic Press, New York, NY, pp. 375–409.
- Huguenin, J.E., Colt, J., 1989. Design and Operating Guide for Aquaculture Seawater Systems. Elsevier, New York.
- SAS Institute Inc. Distributed by Duxbury Press, Pacific Grove, CA.
- Johnstone, H.C., Rahel, F.J., 2003. Assessing temperature tolerance on Bonneville cutthroat trout based on constant and cycling thermal regimes. *Trans. Am. Fish. Soc.* 132, 92–99.
- National Instruments Corporation, Austin, TX.
- Lee, P.G., 2000. Process control and artificial intelligence software for aquaculture. *Aquacult. Eng.* 23, 13–36.
- Minckley, W.L., Douglas, M.E., 1991. Discovery and extinction of western fishes: a blink of the eye in geologic time. In: Minckley, W.L., Deacon, J.E. (Eds.), *Battle against Extinction: Native Fish Management in the American West*. The University of Arizona Press, Tucson, AZ, pp. 7–17.
- Piper, R.G., McElwain, I.B., Orme, L.E., McCraren, J.P., Fowler, L.G., Leonard, J.R., 1982. *Fish Hatchery Management*. United States Department of the Interior, Washington, DC.
- Plaia, W.C., 1987. A computerized environmental monitoring and control system for use in aquaculture. *Aquacult. Eng.* 6, 27–37.
- Poole, G.C., Berman, C.H., 2001. An ecological perspective on in-stream temperature: natural heat dynamics and mechanisms of human-caused degradation. *Environ. Manage.* 27, 787–802.
- Selong, J.H., McMahon, T.E., Zale, A.V., Barrows, F.T., 2001. Effect of temperature on growth and survival of bull trout, with application of an improved method for determining thermal tolerance in fishes. *Trans. Am. Fish. Soc.* 130, 1026–1037.
- Sinokrot, G.A., Stefan, H.G., 1993. Stream temperature dynamics: measurements and modeling. *Water Resour. Res.* 29, 2299–2312.
- Widmer, A.M., 2004. Upper temperature tolerance of loach minnow under acute, chronic and fluctuating thermal regimes. MS thesis. University of Arizona, Tucson.